



## New “NEXGEN” Seat Securement SERVICE NOTICE #17-0831



### **2” Seat Washers NOT Required**

As we explained in Sales Update #17-05, Blue Bird and Microbird are releasing a new seat referred to as the “NEXGEN” Seat! With the new seat, bolt securement requirements to the floor have changed.

Previous seats on the Type C & D Blue Birds, the bolts used were 5/16” and required a 14 gauge X 2” washer on ALL the bolts. The new seats have a single stamped leg with 3 flange bolts that are 1/2”. The nuts are flanged as well and have a 7/8” flange. The front bolts no longer require washers (FIGURE#1). The 2 rear bolts, which are positioned in the reinforced portion of the seat leg, require a .180 plate (FIGURE #2).

ALL of our Service Updates can be found on the [New York Bus Sales website](#)  
Or at the [New York Head Mechanic website](#)

This was presented to NYSDOT and Rusty Seastrum responded that “Whereas the Federal Motor Vehicle Safety Standards current seating securement performance standards were upgraded subsequent to the effective date of 720.4 (P)(2)( c ), and thereby mandating a stronger seat attachment, and the washer requirement is inferior to current designs of seating securements, the washers are therefore not required.”

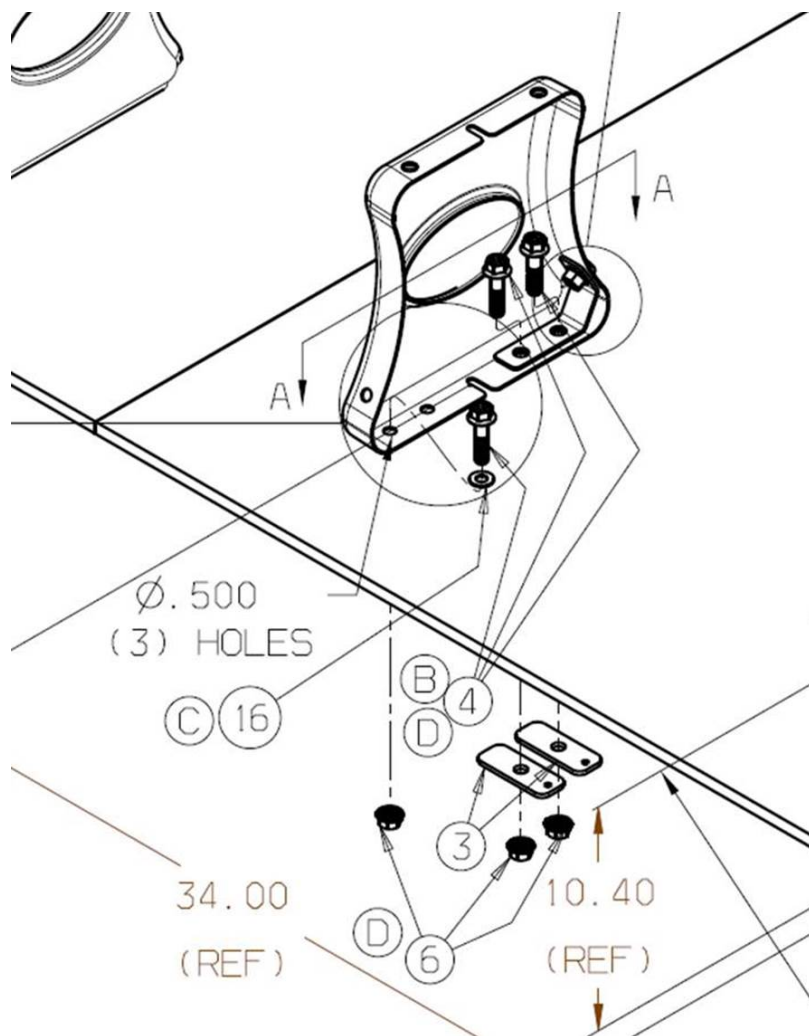

FIGURE #1

ALL of our Service Updates can be found on the [New York Bus Sales website](#)  
Or at the [New York Head Mechanic website](#)

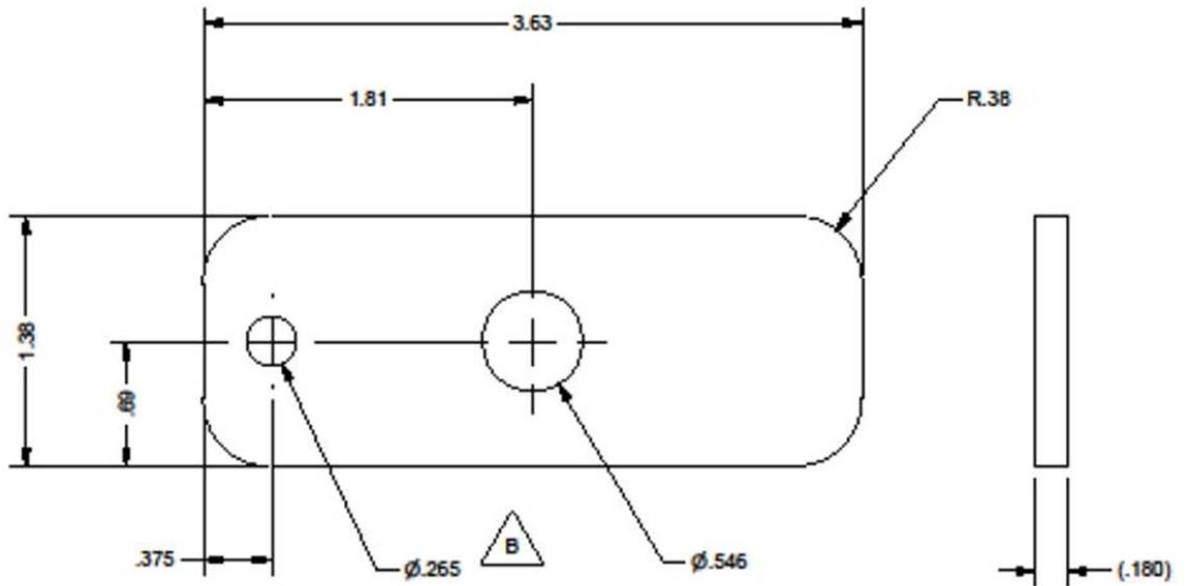

FIGURE #2

ALL of our Service Updates can be found on the [New York Bus Sales website](#)  
 Or at the [New York Head Mechanic website](#)

## CONTACT OUR SERVICE OR PARTS DEPARTMENT WITH ANY QUESTIONS

### SERVICE

**Chittenango:** 800-962-5768  
Daryl Wallace or Brian Lamaitis

**Rochester:** 800-463-3232  
Dave Schaub

**Albany:** 866-867-1100  
Ben Reiling

**Warranty:** 800-962-5768  
Morgan Jenkins

**Customer Service  
Representatives**

**Eastern Region:**  
Gary Bigness  
845-500-3707

**Central Region:**  
JJ Richmond  
315-559-3999

**Western Region:**  
Mike Panzica  
716-908-3186

### PARTS

**Director of Parts**  
Jim Hogan  
jhogan@newyorkbussales.com  
607-227-5794

**Chittenango:** 800-962-5768  
Gari McQuade  
gmcquade@newyorkbussales.com  
Bill Cox  
bcox@newyorkbussales.com  
John Lewin  
jlewin@newyorkbussales.com  
Dave Grant  
dgrant@newyorkbussales.com

**Albany:** 866-867-1100  
Sean Conway  
sconway@newyorkbussales.com  
Pat Murphy  
pmurphy@newyorkbussales.com

**Rochester:** 800-463-3232  
Dave Cook  
dcook@newyorkbussales.com  
Steve Hibbard  
shibbard@newyorkbussales.com

ALL of our Service Updates can be found on the [New York Bus Sales website](#)  
Or at the [New York Head Mechanic website](#)

