

# Sales Update

FROM YOUR FRIENDS AT  
NEW YORK BUS SALES!



## Rear View Mirrors

Recently we have had questions concerning rear view mirrors and some of the differences concerning them. Blue Bird offers the Rosco line of mirrors on its units and there are some variations to the offerings which we thought that we would high light in this update.

The “standard” offering is Rosco’s “Open View” Split System.....in the past this may have been referred to as a “Double Nickle” and has 2 separate mirrors per side, the upper measuring 7-3/8” X 10” and the lower being a convex and measuring 7-3/8” X 5” – Shown in Figure #1 the Blue Bird Option # is 30483-25

The option for the “Open View ES” Split System exists and provides the same upper mirror but provides a larger lower mirror measuring the same 7-3/8” X 10 as the upper. – Shown in Figure #2 the Blue Bird Option # is 30483-19

The option also exists for Rosco’s “Accustyle” mirror which provides both the regular upper mirror and lower convex mirror, only within an 8” X 17” assembly – Shown in Figure #3 the Blue Bird Option # is 30483-28

PLEASE NOTE – ALL THESE MIRRORS CAN BE ORDERED AS HEATED, REMOTE or WITH STAINLESS STEEL BRACKETS!!



IF ORDERED WITH THE REMOTE FEATURE, ALL 4 MIRRORS OF ANY OPTION CAN BE ADJUSTED USING THE SWITCHES ON THE LEFT DRIVER’S PANEL WHICH ARE PICTURED TO THE LEFT.

EACH SWITCH OPERATES A SIDE – THE CENTER WITH THE “O” IS A NEUTRAL POSITION AND TURNING TO EITHER OF THE DOTS OPERATES THE UPPER OR LOWER MIRROR



FIGURE #1



FIGURE #2

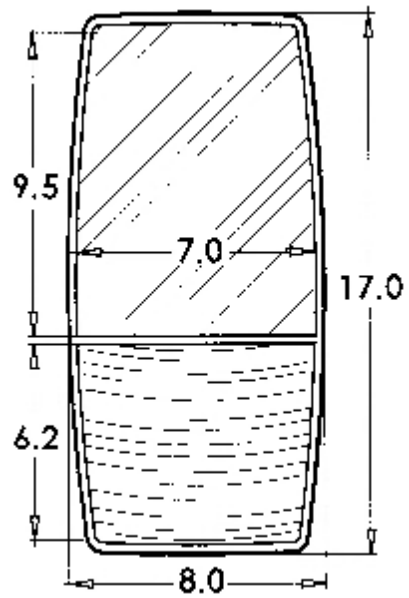

FIGURE #3

**Contact Our Sales Department With  
Any Questions**

Kevin Coon: [kcoon@newyorkbussales.com](mailto:kcoon@newyorkbussales.com)

Cell (315)415-6570

Bill Daigler: [wdaigler@newyorkbussales.com](mailto:wdaigler@newyorkbussales.com)

Cell (716)713-9852

George Darling: [gdarling@newyorkbussales.com](mailto:gdarling@newyorkbussales.com)

Cell (315)263-6141

Jeremy Johnston: [jjohnston2@newyorkbussales.com](mailto:jjohnston2@newyorkbussales.com)

Cell (585)233-3768

Bill Lyons Sr.: [blyons@newyorkbussales.com](mailto:blyons@newyorkbussales.com)

Cell (518)470-0609

Bill Lyons II: [blyons2@newyorkbussales.com](mailto:blyons2@newyorkbussales.com)

Cell (518)275-2816

Jeremie (JJ) Richmond: [jrichmond@newyorkbussales.com](mailto:jrichmond@newyorkbussales.com)

Cell (315)559-3999

