

Tech Tip



From your friends at New York Bus Sales

“Ghost” Electrical Issues and Improper Relays

Complaint - Driver’s are saying that there are some lights that come on and then are not on when we check them or there is a light on in a circuit and we can’t find out why!

Cause - Check the records! Was there something done to address an issue on that circuit previously?

What has been seen is that there may have been an issue where some work was needed and it was repaired and the unit put back in service and operated everything worked as designed.

After sometime operating there seemed to be “ghosts” in that circuit where lights may illuminate and then go out....or maybe a light came on and it can’t be resolved with reason. So the next step is to replace parts and when the relay is replaced, the light goes out so the relay is blamed but we are not sure exactly why.....now we can explain it!

The issue is that there are actually 2 types of relays – Those which operate using a diode AND those which have no added diode! There is a difference in their operation and although when a relay is replaced with an improper relay the system may work fine over time the issue may arise causing the circuit to work improperly!

Correction - Make sure you are using the correct part – Figure #1 shows a relay with the added diode and Figure #2 shows the relay without the added diode.

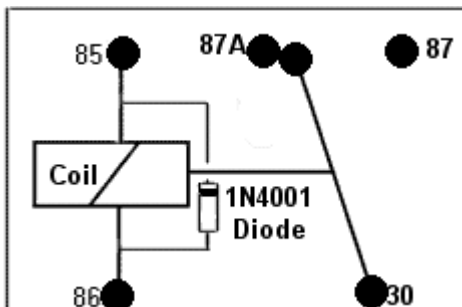

Figure #1

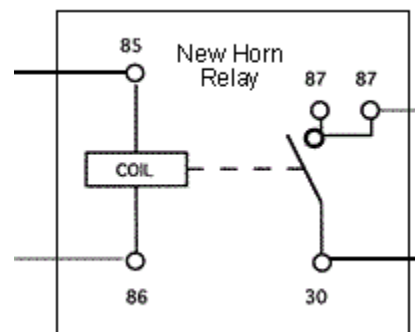

Figure #2



Contact Our Service Department With Any Questions

CHITTENANGO – phone 800-962-5768 or
Daryl Wallace : dwallace@newyorkbussales.com
Brian Lamaitis : blamaitis@newyorkbussales.com

ROCHESTER – phone 800-463-3232 or
Gary Chichester: gchichester@newyorkbussales.com

ALBANY – phone 866-867-1100 or
Ben Reiling: breiling@newyorkbussales.com
Steve Searles: ssearles@newyorkbussales.com

WARRANTY – 800-962-5768 ext 237
Morgan Jenkins: mjenkins@newyorkbussales.com

THANK YOU TO
THE BLUE BIRD TRAINING CREW