

Tech Tip



From your friends at New York Bus Sales

- Complaint -** There is a coolant leak which appears to be coming from the water pump. The spray is so fine that it is very hard to detect where it is coming from!
- Cause -** There is a plug in the back of the water pump (item #4 in figure #1) and a hole has formed in the plug which sends a “minute” stream of coolant from the plug -
- Correction -** Drain cooling system, remove the bad plug and replace with new plug and “O” ring.

PLEASE NOTE – If new plug is not available as a “TEMPORARY” repair the old plug can be removed and JB Weld or a similar product used to seal the hole in the plug.

Nitrate levels in the coolant should be checked to assure they are within specs and did not contribute to the failure

*Thank You
To Phil Peck from Sherman CS
&
Joe Goodway from Pine Valley CS
For pointing this out to us!!!*

*Part Numbers
PLUG – #9S-8003
“O” Ring – #1J9671
CAT Coolant Test Kit – #4C-9301*

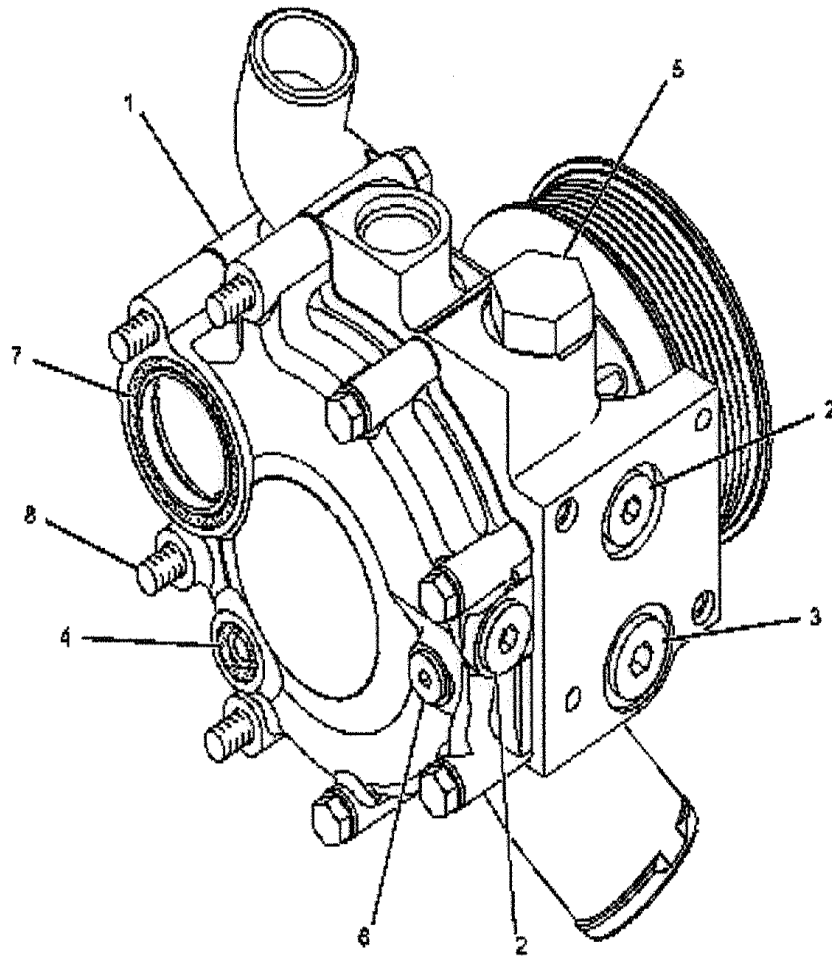

Figure #1



Contact Our Service Department With Any Questions

CHITTENANGO – phone 800-962-5768 or

Daryl Wallace : dwallace@newyorkbussales.com

Brian Lamaitis : blamaitis@newyorkbussales.com

ROCHESTER – phone 800-463-3232 or

Gary Chichester: gchichester@newyorkbussales.com

ALBANY – phone 866-867-1100 or

Ben Reiling: breiling@newyorkbussales.com

Steve Searles: ssearles@newyorkbussales.com

WARRANTY – 800-962-5768 ext 237

Morgan Jenkins: mjenkins@newyorkbussales.com

ALL of our Tech Tips can be found on the New York Bus Sales website at

<http://www.newyorkbussales.com/pages/bulletins.cfm>

Or at the New York Head Mechanic website at

<http://www.nvhma.org/viewforum.php?f=2&start=0>

